

visit the website



DOWNTOWN STOOL

design by CHRISTOPHE PILLET

Stool with PU-covered seat. Adjustable height with gas pump.
Chrome metal structure.
Equipped with standard black wheels



The information contained in this technical document is correct and accurate to the best of our knowledge, and should therefore be considered reliable. In any case, they cannot imply a guarantee on our part, as certain factors such as the working of the products, are outside our strict control. It is responsibility of the user to verify the suitability of the products for the specific use, as well as the precise and accurate installation in accordance with the guide-lines provided within the instruction manual and according to the current regulation regarding the purpose of the business activity. It should be noted that the packages indicated may vary due to the production efficiency improvement. This document replaces all previous versions. For further information it is recommended to contact our sales department.



NIO
SPA DESIGN



DOWNTOWN STOOL N9405

Stool with castors and seat upholstered in Soft PVC Base an aluminum.
Height adjustable with gas pump



Skay and Woods



Patents and Certifications

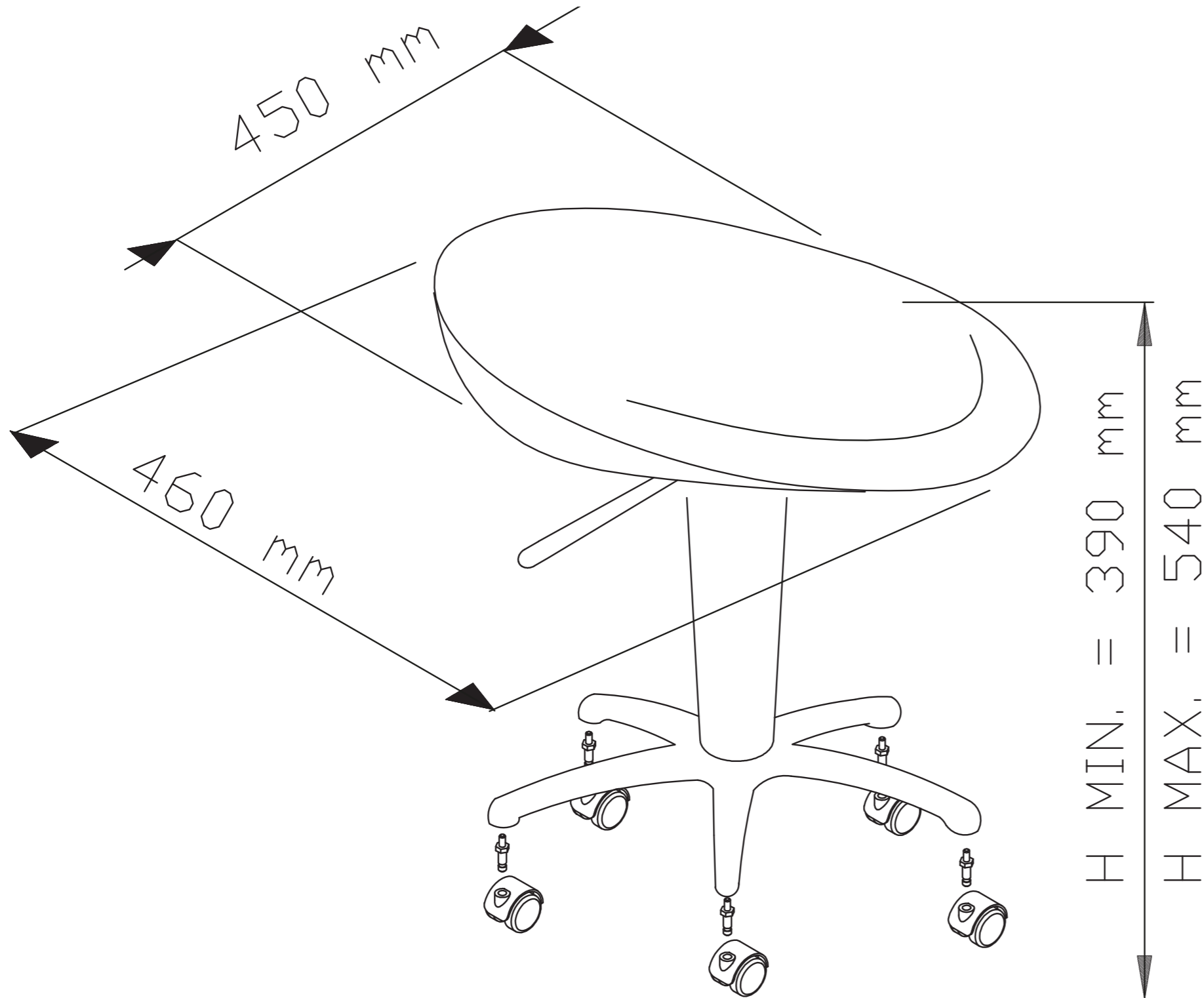

TECHNICAL SPECIFICATION		
UPHOLSTERY	SKAY PVC NILO	
OPTIONAL	AVAILABLE	NOT AVAILABLE
SPPEDY SILICON WEELS	*	
MEASUREMENT		
MAXIMUM LOAD CAPACITY	120 KG	
MEASUREMENTS	→ 45 ↖ 46 ↑ SEAT 39/54 CM - 5 KG	
PACKAGING	BOX → 56 ↖ 55 ↑ 87 CM - 8 KG	